



Leer, Inc.
206 Leer Street, P.O. Box 206
New Lisbon, WI 53950
1-800-766-5337
www.leerinc.com

PL and TD
INSTALLATION, OPERATION, AND SERVICE
MANUAL



WARNING: This product can expose you to chemicals including nickel, which is known to the State of California to cause cancer (For more information go to www.p65warnings.ca.gov)

Table of Contents

Start-UP	3
Storage and Transportation:	3
Packaging:	3
Installation	3
Placing Merchandiser:	3
Merchandiser Leveling:	3
Electrical:	3
Plug Units:	4
Condensate Evaporator:	4
Operation	4
Temperature Controls:	4
Mechanical Controls Thermostat:	4
Mechanical Controls: Defrost Timer:	5
Electronic Controls: Digital Display:	5
Operating Mode Display:	5
Electronic Control Operation:	5
Auto-Defrost Control:	5
Possible Displayed Alarm Codes:	5
Loading Ice:	6
Maintenance	6
Cleaning the Merchandiser:	6
Cleaning Door Gaskets:	6
Cleaning Condenser Coils:	7
Defrosting the Merchandiser:	7
Auto-Defrost Mechanical Timer	7
Auto-Defrost Electronic Control:	7
Glass Door Models and Maintenance:	8
Solid Door Models and Maintenance	8
Hinge Spring Tension	8
Door Gaskets and Hardware	8
Electronic Control Wiring Diagram	10
Mechanical Control Wiring Diagram	11
Side Pallet Load Ramp	12
Pallet Load Front Installation / Loading	13
Installation:	13
Loading:	13
Warranty	14

Start-UP

Storage and Transportation:

The merchandiser should be stored and transported in an upright position. It is not recommended to tilt the merchandiser. If the merchandiser is tilted beyond 45 degrees of vertical, oil may drain from the compressor casing premature failure.

Do Not stack merchandisers on top of one another due to risk of falling. Falling merchandisers could result in damaged units or serious injuries. It is recommended to use warehouse racking design to accommodate the weight of the merchandisers and prevent falling.

Packaging:

Prior to installation, the outer packaging on the merchandiser will need to be removed. The majority of the packaging materials can be recycled and disposed of in an environmentally friendly manner. Glass door models are shipped with door support brackets installed between the merchandiser's door opening(s) and the bottom rail of the door. These support brackets must be removed prior to operation of the merchandiser. Failure to remove the brackets will affect the seal of the door gasket to the cabinet face.

Installation

Note: Leer Ice Merchandisers are commercial in design and not intended for residential use

Placing Merchandiser: When placing the merchandiser, allow a minimum of 3 inches of air space from all surfaces of the cabinet and any surrounding structures. This air space allows for air flow over the surface of the cabinet, thus reducing condensation and aid in the drying of these surfaces. On outdoor auto-defrost models, the 3 inch space behind the merchandiser will also help ensure that the evaporator drain tube, which exits the back wall, is not being restricted during the defrost cycle. For Pallet Load Front Units see the special instructions at the end of this manual.

Merchandiser Leveling: The merchandiser installation location should have a solid, level base. If the merchandiser is exhibiting a slight lean, the cabinet should be blocked to bring the cabinet to a level position. On auto-defrost models, a lean, opposite the direction of the drain may affect proper draining of the unit cooler assembly during the defrost cycle.

Electrical:

Warning! Component parts shall only be replaced with like components. Electrical and refrigeration repair work should be done by licensed professionals. Disconnect power before performing service. Certain models contain multiple voltages. Leer does not assume responsibility for any damage to people or things deriving from violation, improper use or in any case not in compliance with Leer's instructions.

The Merchandiser must be plugged into a dedicated and properly grounded 115V/60hz/1Ph circuit with a circuit fuse or breaker rated at a 15 or 20 Amps depending on model. The electrical service connections to the merchandiser must be compliant with the National Electric Code and any local codes that may apply. **DO NOT** use extension cords. Models that come with the 20 Amp plug configuration should not be removed. Models covered in this manual come with a main power switch. Make sure the switch is in the OFF position before plugging the merchandiser into the outlet. Plug the merchandiser power cord into the lower receptacle of the electrical outlet. Turn the switch into the ON position. After a few seconds delay, the compressor and the condenser fans should start. The evaporator fan motors and the light fixture should start immediately when power is applied. The condensing unit will continue to run until the air temperature in the cabinet reaches +16° F.

WARNING: Operating more than one appliance on the same circuit may result in voltage fluctuations when both appliances are operating simultaneously. This voltage fluctuation may cause the circuit breaker to trip off and/or cause voltage drops. As a result, the power to the

merchandise may be interrupted and freezing performance can be adversely affected which may cause equipment damage and /or product loss. Voltage supply to the merchandise must not vary more than $\pm 10\%$ of the normal 115V. Information regarding the electrical voltage and frequency being supplied to the merchandise can be found on the merchandise's serial data plate typically located at the upper left corner of the merchandise's interior. Information regarding the maximum fuse/circuit breaker size required for the specific model is available from the condensing unit data plate.

Plug Units: Units that have a plug style condensing unit and evaporator will need to be unpackaged and installed on top of the unit. The completed plug weighs approximately 150 pounds. An appropriately rated, mechanical lifting device should be used to prevent injury. If one is not available and due to the weight of the plug unit, it is recommended to use a two person lift to manually install. Use caution to prevent damage to the drain pan nipple upon installation. Do not lay the evaporator housing directly on any surface as the weight of the compressor could damage the fans or drain nipple. Once installed, lighting and door switch connections (if applicable) will need to be made on top of the unit.

Condensate Evaporator: Indoor auto-defrost models are supplied with a condensate evaporator heater assembly which is packaged and shipped inside the merchandise. It will require simple installation by the consumer (see **Figure 1**). A separate copy of this instruction sheet is supplied with the condensate evaporator assembly. The condensate evaporator assembly contains a drip pan to collect water generated by the merchandise's defrost cycle and a heat element to evaporate the water. Once energized, the heat element in the condensate evaporator assembly is continuously generating heat. The merchandise is to be placed so that there is at least 1 inch of air space between the back surface of the condensate evaporator housing and any wall surface behind the cabinet which allows for heat dissipation away from the surface of the wall. The main power cord should also be routed to avoid pinching.

Note: Do not operate an indoor auto-defrost merchandise without having a condensate evaporator assembly installed under the evaporator drain tube exiting the back wall of the cabinet. Failure to install this assembly will result in water draining directly onto the floor during the defrost cycle. This may result in water damage to the floor and create a hazardous slip condition in the area surrounding the merchandise.

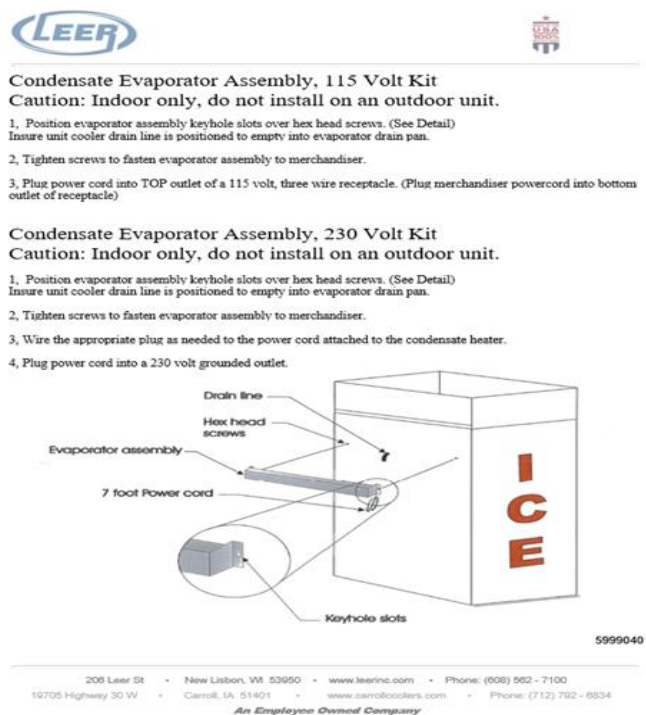

Figure 1: Condensate Evaporator Installation

Operation

Temperature Controls: Certain Merchandisers are currently available with either mechanical controls (optional) or an electronic control (standard). Contact Leer for information.

Mechanical Controls Thermostat:

The compressor is controlled by the classic thermostat where the engagement and disengagement of the thermostat is controlled by the expansion and contraction of gas within a sensing tube. Merchandisers with mechanical thermostats are factory set to operate at a cut-out temperature of 18° F +/-2°. The thermostat has an adjustment knob that allows a limited adjustment range. Rotating the adjustment knob clockwise will lower the cabinet temperature while a

counter-clockwise rotation will raise the cabinet temperature. Rotating the adjustment knob fully counter-clockwise will shut off power completely to the merchandiser’s condensing unit. The thermostat has a pre-set differential of 7° F, which is not adjustable.

On automatic defrost (AD) cabinet models, the thermostat is housed inside the unit cooler assembly that is mounted to the interior ceiling of the cabinet.

Mechanical Controls: Defrost Timer:

The defrost timer is located under the condensing unit housing. The timer will engage the merchandiser’s defrost cycle once every 4 hours for a duration of 16 minutes. The timer may be manually advanced into defrost by rotating the advancement knob in a clock-wise direction. Manual advancement into the defrost mode will re-set the next controlled defrost cycle to take place in 4 hours.

Electronic Controls: Digital Display:

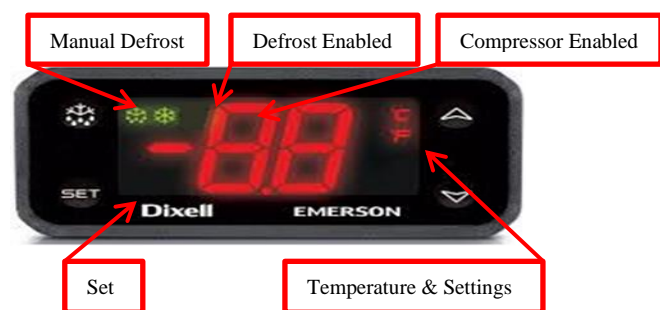

Operating Mode Display:

- Snowflake “ON” – compressor enabled in run cycle; control displays current cabinet temperature.
- Snowflake “Flashing” – anti short cycle delay enabled to protect the compressor from trying to start too frequently.
- Melting Snowflake “ON” – defrost in progress, control displays the letters “DE”
- To view the control’s programmed “Set Point” (cut-out temperature): press and release the “Set Key.”
- To initiate a manual defrost cycle: press and hold the “Manual Defrost Key” for more than 2 seconds.

Note: Manual Defrost will not initiate unless the unit is at standard operating temperatures.

Electronic Control Operation:

The electronic control combines the functions of both the mechanical thermostat and defrost timer into a single control. The control also offers the consumer the capability of monitoring the operational status of the merchandiser via the icon and digital temperature display (located on the face of the control). The controller has been programmed by Leer to operate the merchandiser within the design parameters of the refrigeration system. The set-point (cut-out) for these controls has programmed parameters for 16° F, with a differential of 8° F. Should the user desire to alter the Set-Point, the new set-points should not exceed +/- 4° of the original factory setting. Do not alter any of the programming parameters in the controls without first consulting with Leer.

Auto-Defrost Control: The AD control is located under the condensing unit cover and contains two thermal-couple probe wires. Both probe wires are routed through the cabinet’s suction line hole and into the unit cooler assembly, which is mounted to the interior ceiling of the cabinet. The Red Air Sensing Probe (“P1”) routes through the unit cooler and has its’ sensing bulb secured to the outer, left-hand wall of the unit cooler. Probe “P1” monitors the air temperature in the merchandiser at that location. During the normal operation of the control, the digital display will show the cabinet temperature at the probe “P1” location. The Black Probe “P2” is inserted into the finned section of the evaporator coil, near the top of the unit cooler assembly. This probe monitors the temperature of the evaporator coil during the defrost cycle.

Possible Displayed Alarm Codes:

- “P1” – Air Probe failure: The control will override the “P1” functions and cycle the compressor at 5 minute intervals, until the probe fault can be corrected.
- “P2” – Evaporator Probe failure: The control will override the “P2” function and operate with a

timed defrost cycle, until the probe fault can be corrected.

“HA” – Maximum Temperature Alarm: The cabinet air temperature has exceeded programmed temperature for a period exceeding 15 minutes. The alarm will continue to display until the cabinet temperature drops below maximum levels.

“LA” – Minimum Temperature Alarm: The cabinet air temperature has dropped below the programmed minimum. This alarm will continue to display until the cabinet temperature rises above the minimum level.

Note: Should a “P1” or “P2” alarm occur, check the probe wire connections to the control prior to replacing the probe wire.

For more detailed information regarding the Electronic Control programming and instructions, please contact: Leer, Inc. Merchandiser Division Customer Service. Phone: 800-766-5337. Contact information is available on our web-site at <http://www.leerinc.com/ice-merchandisers/merchandiser-sales-distributors/>

Loading Ice: The merchandiser should be pre-chilled prior to loading with ice. Pre-chilling will aid the merchandiser in reaching storage temperature at a faster rate once loaded and reduce the risk of melting product. Do not over fill the merchandiser with ice!

Avoid stacking ice above the top edge of the air ducts that are installed on the walls of the cabinet interior. Blocking off these air ducts may restrict the even distribution of cold air throughout the cabinet which may result in warm spots developing within the cabinet. Also, do not stack ice high enough to block off the evaporator fans in the unit cooler assembly. The evaporator fans are intended to pull warm air entering the cabinet into the unit cooler and then push that warm air across the surface of the evaporator coil. This process removes the heat prior to distributing the air into the cabinet.

Maintenance

Note: Component parts shall only be replaced with like components. Maintenance and repair of the electrical and refrigeration systems should only be done by trained and qualified personnel. Disconnect power before performing service. Certain models may contain multiple voltages. Leer does not assume responsibility for any damage to people or things deriving from violation, improper use, or in any case not in compliance with Leer’s instructions.

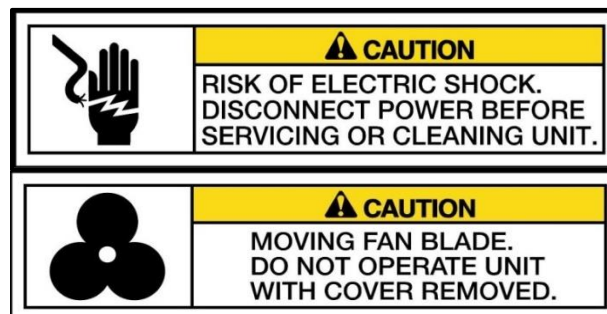

Cleaning the Merchandiser: The merchandiser should be cleaned annually. In corrosive environments such as coastal regions and areas where deicing chemicals and road salts are used, more frequent cleaning is recommended. The exterior of the merchandiser can typically be cleaned with the use of detergents diluted in warm water followed with a tap water rinse. The exterior paint is capable of withstanding the use of polishing compounds and most solvents. If using stronger cleaning agents, they should be tested on a small, inconspicuous areas prior to application. If cleaning the interior of the merchandiser, the use of detergents with strong odors (i.e. citrus based cleaners), abrasive cleaners containing chlorine bleach, and any form of solvent based cleaners are not recommended. They may leave objectionable odors inside the cabinet which may be absorbed by the ice being stored in the merchandiser.

Cleaning Door Gaskets: Door gaskets may mildew and stiffen over time. The gasket is made of a soft, flexible rubber-like material that can be cleaned using most kitchen and bath cleaners designed for mildew removal. Review manufacturer information and instructions on any

cleaning agent prior to use to determine the cleaner's compatibility with the surface being cleaned.

Cleaning Condenser Coils:

It is recommended to inspect and clean the condenser coil and fan blades every 3 months. There are a variety of methods available for cleaning the condenser coils. Keep in mind that the debris is being drawn into the coil by the condenser fan and the debris should be removed in the opposite direction.

- The simplest and preferred method would involve the use of a vacuum cleaner to suck the debris out of the coil from the outside surface.
- Another method is using compressed air to blow dust from the coil. The debris should be blown out from the inside surface of the coil.

WARNING: When using compressed air, there may be a cloud of dust released into the air surrounding the machine.

It is recommended that the service person wear the proper protective equipment (i.e. safety glasses and a dust mask) when performing coil cleanings.

Note: DO NOT use any type of filter media in front of the condenser coil to trap dust. Filter testing has proven to create enough restriction of air flow to reduce the efficiency of the coil's heat exchange.

Defrosting the Merchandiser:

The Auto Defrost merchandiser is designed to be self-defrosting. The heat generated by the defrost heater element will melt the ice build-up on the evaporator coil and the resulting water will drain through a tube out of the back wall of the machine.

It is recommended to check the operation and condition of the evaporator coil and for signs of excessive ice buildup every 3 months

Auto-Defrost Mechanical Timer: The AD merchandiser may come equipped with a mechanical timer (as described in the **Operation** section of this manual). The timer is factory set for a 15 minute defrost cycle to occur at 4-hour

intervals. During its' run-cycle, the timer supplies power to the thermostat, condensing unit, and evaporator fan motors. During the defrost cycle, the timer switches power from the run-circuit to the defrost-circuit and energizes the defrost heater. The AD mechanical timer may be manually advanced to a defrost mode by rotating the advancement knob (located on the back of the timer) in a clockwise direction until the defrost switch engages. The advancement knob rotates in a clockwise direction only.

The mechanical defrost circuit is equipped with a defrost termination switch and is attached to one of the evaporator coil tubes (located inside the Unit Cooler Assembly). This switch senses temperature and will cut power to the defrost heat element should the temperature at the surface of the switch reach 70° F. This switch terminates power to the heat element and will not end the timed defrost cycle. Once the unit has returned to run mode, the termination switch will re-set when the temperature at its' surface reaches 30° F.

Auto-Defrost Electronic Control: For Merchandisers with an electronic control (as described in the OPERATION section of this manual). The timer is factory set for a 24 minute defrost cycle to occur at 4-hour intervals. Like the mechanical timer, the electronic control will switch power from run mode (condensing unit and evaporator fans) to defrost mode (defrost heat element). Whereas the mechanical timer operates strictly on a timed cycle, the duration of the electronic control's defrost cycle is controlled by the temperature at the sensor probe "P2." If the temperature at this probe reaches 60°F prior to the 24-minute timed cycle ending, the control will override the timed cycle and immediately switch power from the defrost mode to a drip time then standard run mode. If temperature is not reached at probe "P2," the defrost cycle will continue for the entire 24- minute programmed cycle prior to returning to run mode. Energizing the defrost circuit in the electronic control can be verified with the illumination of the "melting snowflake" and the letters "DE" appearing on the control's display.

The electronic defrost circuit is equipped with a defrost termination safety switch and is attached to one of the evaporator coil tubes (located inside the Unit Cooler Assembly). This switch senses temperature and will cut power to the defrost heat element should the temperature at the surface of the switch reach 100° F. This switch only terminates power to the heat element and will not end the timed / temperature defrost cycle. Once the merchandiser has returned to run mode, the termination safety switch will re-set when the temperature at its' surface reaches 70° F.

Warning! The defrost termination / safety switch functions as a possible fire protection device. Do not remove or by-pass the switch from the defrost circuit.

Note: If an electronic control AD unit loses power and the temperature at "P2" is less than 60°F, it will automatically enter a defrost cycle after a two-minute delay.

Glass Door Models and Maintenance:

The glass door is designed for use on indoor units or a controlled environment. It is constructed with a non-heated, triple-pane glass-pack, with both inner and outer panes being tempered. To avoid possible condensation on the outer surface of the door, case temperature in the merchandiser should be maintained near its' designed set-point of 16° F +/- 4° and ambient dew-points around the cabinet location should be kept below 60°F. Any household glass cleaner can be used to clean the door surface.

Solid Door Models and Maintenance:

Cabinets designed for outdoor use will have a metal clad door that has been insulated with the same urethane foam insulation as the cabinet. The exterior metal is stucco embossed to hide minor impacts and is coated with a fluorocarbon paint system. This paint system was designed to withstand years of outdoor exposure. For routine cleaning of the door's exterior surface, a mild detergent diluted in warm water should be adequate.

Hinge Spring Tension: A simple test of the spring-load tension is to open the door just enough to insert two fingers between the surface of the cabinet and the handle side of the door. When the fingers are withdrawn, there should be enough tension set on the hinge spring-loads to slowly move the door to a closed position. If the door does not move from this two-finger location, it's likely that either the spring-load requires re-tensioning or lubrication. If the door moves part way from the two-finger location but stops short of the cabinet, the compression of the gasket along the hinge side of the door should be checked. If there is too much compression, the door will bind when closed and should have its hinge-mount location checked and possibly adjusted. Removing the hinge covers will expose the spring-loads for tension adjustment or removal. Removal of the spring-load will expose the hinge-adjustment plate and mounting screws should hinge adjustment be required. See **Figure 2** for instruction regarding spring-load installation and adjustment.

Door Gaskets and Hardware: Routine inspection of the door gasket seal and the action of the door's hinges are recommended. If damage has occurred to the gasket, it may allow outside air to penetrate the cabinet and the gasket should be replaced.

SPRING CARTRIDGE INSTALLATION INSTRUCTIONS

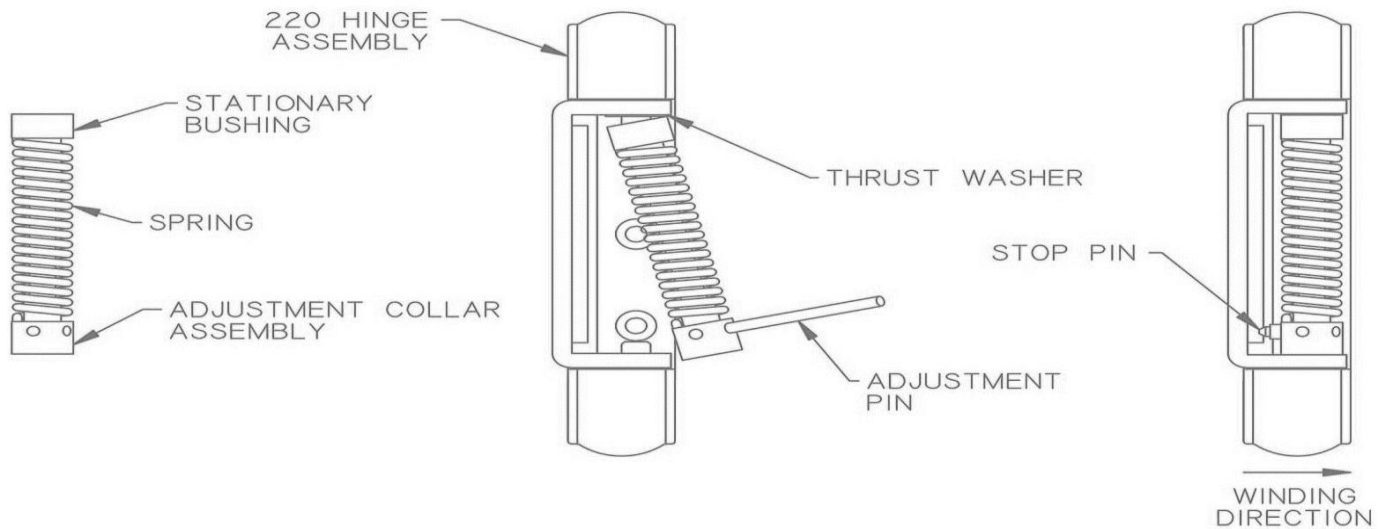

Figure 1

Figure 2

Figure 3

- 1) Install No. 220 Hinge with Adjustment Plate.
- 2) Assemble Spring Cartridge. Grease bushing end of pin prior to insertion into Stationary Bushing. Apply a small amount of grease to the hinge-pin hole on the end of the Adjustment Collar Assembly. (Fig. 1).
- 3) Place Thrust Washer and Stationary Bushing over square pin in the Hinge and insert the Adjustment Pin into the Adjustment Collar. Using the Adjustment Pin, compress the Spring and place the Adjustment Collar over the round pin (Fig. 2).
- 4) Using the Adjustment Pin, turn the Adjustment Collar until the Pin contacts the Hinge. Then insert the Stop Pin in hole of Adjustment Collar (Fig. 3). **CAUTION:** The Stop Pin must fully seat on Adjustment Collar. Failure to do so may cause the Stop Pin to become dislodged. Inserting the Adjustment Pin more than half way thru the Adjustment Collar can cause partial push out of the Stop Pin. Repeat adjustment until desired tension is reached. The maximum tension is 6 holes or approximately 1-1/4 turns.
- 5) Install Cover on Hinge.

WARNING: Use safety glasses when installing and adjusting spring tension.

Figure 2: Spring Install Instructions

Electronic Control Wiring Diagram

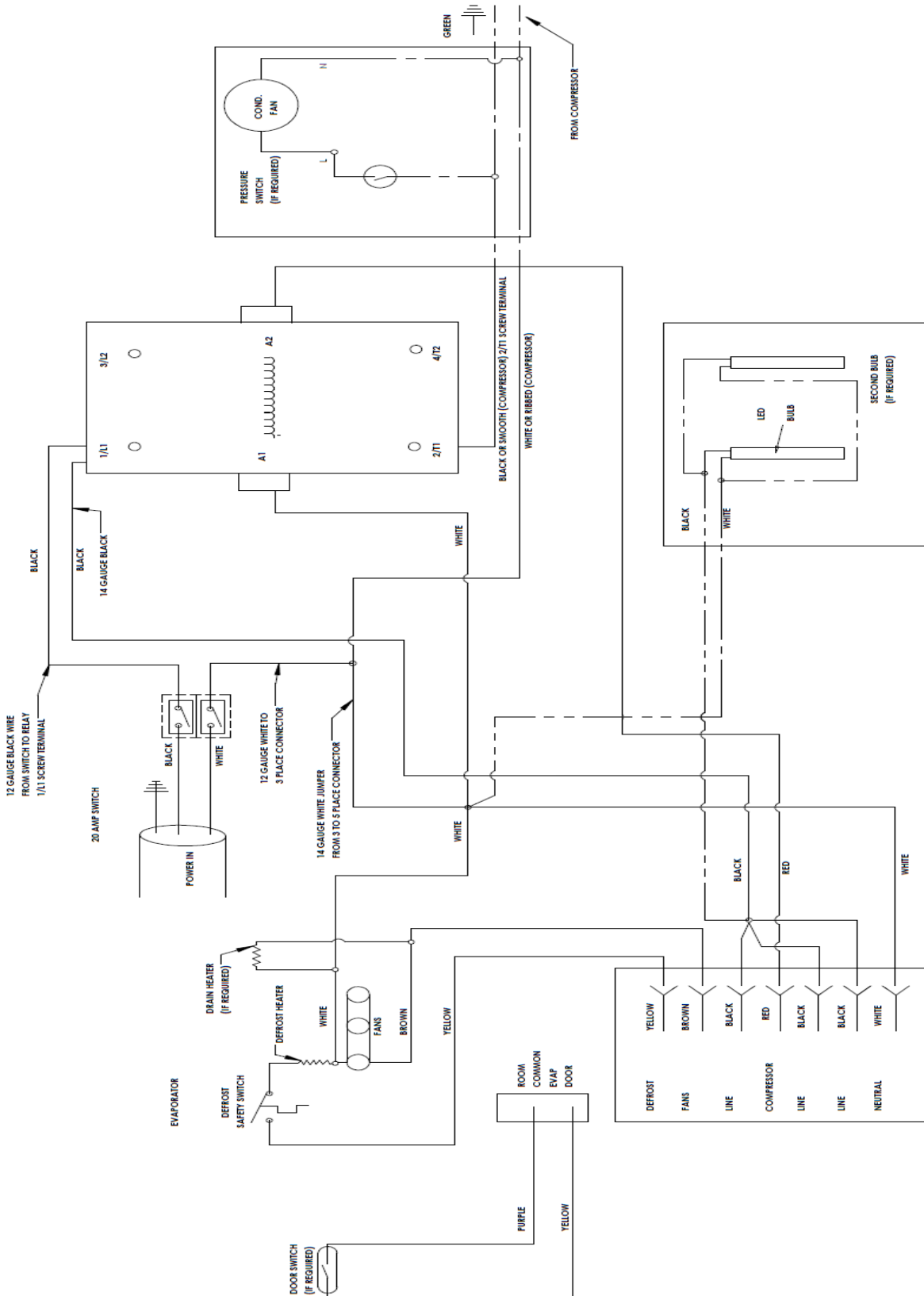

Mechanical Control Wiring Diagram

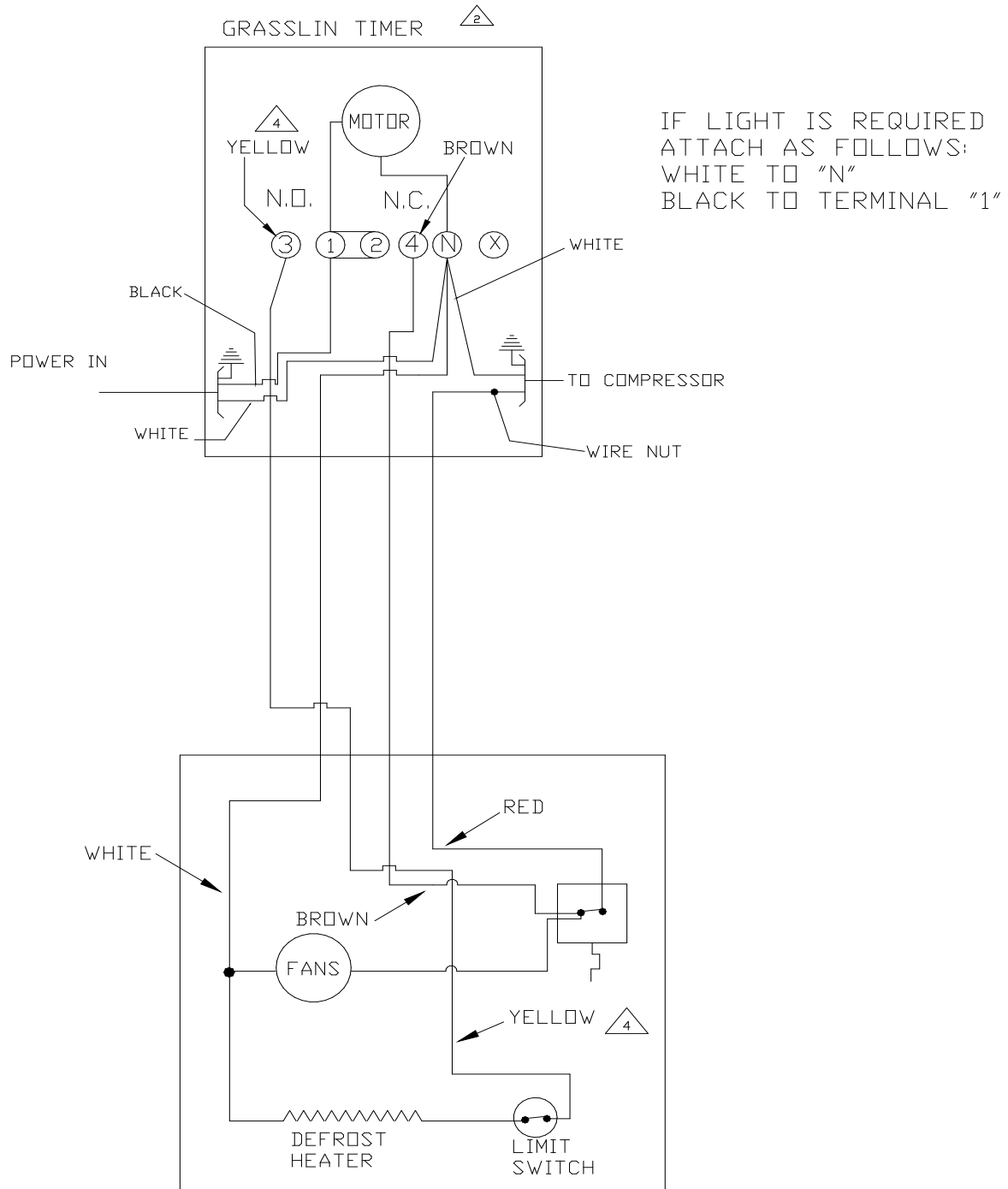

Side Pallet Load Ramp

Remove the ramps from the back of the cabinet and place the tallest ramp onto the door threshold.



Lock the ramp into place using the slide bolts located below the threshold of the pallet load.



Connect each ramp by the groove and stud.



Repeat this process for ramp 3



Repeat for ramp 4.



Move the ice into the Pallet Load.



Set the ice into place and remove the pallet jack.



Remove the ramps and replace onto the back of the unit. Close the doors when finished.



To view a video of this process please visit:
www.leerinc.com

Pallet Load Front Installation / Loading

Installation: The installation of the PLF (Pallet Load Front) is different than a standard Merchandiser, Tall and Deep or Pallet Load.

It is recommended to place the PLF on a solid - level surface.

It is recommended to use the supplied aluminum back stop, and have it securely fastened to the floor at least 4" away from any obstruction. Having the unit set against the backstop will help prevent movement during the loading process.

Attach the condensate pan to the back of the unit at this time.



To move the unit, Insert an empty base pallet into the lift channels. Lift the unit with a pallet jack by the base pallet.



Move the box into place firmly against the aluminum back stop. Lower the pallet jack and remove the base pallet.

The unit has a rubber gasket that will seal the unit from the outside. Do not move the unit without the aid of a pallet jack. Doing so will cause damage to the gasket.

Remove the lift channels before putting the unit into operation. The lift channels are secured using 8, 1/2" drive bolts. Reinstall bolts to hold aluminum trim pieces.



Retain the lift channels for use later.

Loading:

Place the pallets of ice directly on the base pallets.



Align the base pallet and ice with the aluminum trim. Push the ice into the unit using a pallet jack. Lower the pallet and remove the jack.

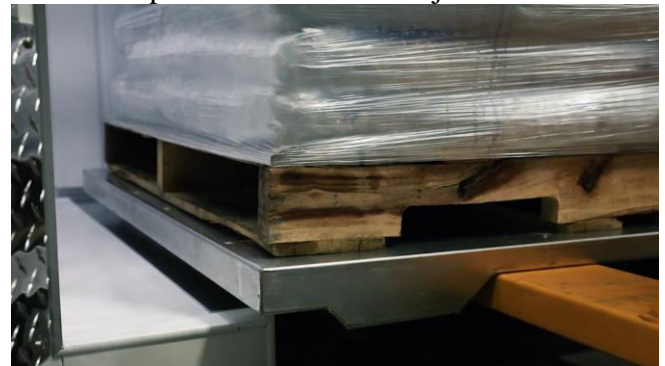

Close the doors and latch the right side.

Warranty

PL AND TD MERCHANDISERS: Seller warrants the merchandiser under normal use and service, for one (1) year for the component parts (to be shipped by seller), and ninety (90) days for repair labor from the date of original shipment. The merchandiser compressor motor is warranted for five (5) years from the date of original shipment. SELLER MUST BE CONTACTED AND PROVIDED A MERCHANDISER SERIAL NUMBER FOR WARRANTY CLAIM. This applies only to goods installed in the United States, Canada or Mexico. Seller's obligation under this warranty shall be limited to repair (subject to the limitations below) or replacement of any part(s), F.O.B. Seller's factory, which prove(s) defective within the applicable warranty period. Seller reserves the right to inspect defective part(s) and may at Seller's discretion require return of part(s) to Seller's factory for inspection. The determination as to whether any defect exists shall be made in Seller's sole judgement.

GENERAL PROVISIONS APPLICABLE TO ALL WARRANTIES AND PRODUCTS: Seller shall not be liable for any breach of any express warranty set forth above unless Seller is informed immediately upon the discovery of defective part(s). The warranties described above are not assignable and shall operate only in favor of the original buyer/user. In event of any claim for breach of express warranty, Seller shall be responsible for labor charges for repair or replacement of any defective part(s) or assembly only for defects reported to Seller within ninety (90) days after the date of installation. ALL LABOR CHARGES SHALL BE AUTHORIZED OR APPROVED BY SELLER PRIOR TO THE REPAIR OR REPLACEMENT OF PART(S). In all other events, Seller shall not be responsible for any labor charges. Labor charges shall only include standard straight time labor hours at the site of product installation, and shall exclude charges for travel time, mileage, or other premium charges. These warranties shall not apply to any goods, or any part thereof, which may have been subject to any damage in transit, accident, negligence, abuse or misuse, unauthorized alteration or repair, acts of nature or failure to follow any of the Seller's manuals or instructions, if in Seller's sole judgement, such act, omission or event has detrimentally affected the physical condition, use or operating qualities of the product.

SELLER MAKES NO WARRANTY, EXPRESS OR IMPLIED, BY REASON OF LAW, STATUE OR OTHERWISE, INCLUDING ANY IMPLIED WARRANTY OF MERCHANTABILITY OR FITNESS FOR A PARTICULAR USE OR PURPOSE, AND ALL IMPLIED WARRANTIES ARE HEREBY DISCLAIMED. SELLER SHALL NOT BE LIABLE FOR LOSS OF GOODS, MERCHANDISE OR OTHER PROPERTY, OR LOSS OF PROFITS, RESULTING FROM PRODUCT DEFECTS. IN NO EVENT SHALL SELLER'S LIABILITY UNDER ANY CIRCUMSTANCES FOR ANY BREACH OF CONTRACT OR FOR ANY OTHER CLAIM BY BUYER AGAINST SELLER EXCEED THE CONTRACT PRICE OF THE GOODS SOLD HEREUNDER WITH RESPECT TO WHICH SUCH CLAIM ARISES.

MODEL NO. _____

SERIAL NO. _____