



**REFRIGERATED TRAILERS**

**Model 5 x 10 Trailer**



**Trusted Partner in  
Temperature-Controlled  
Storage Solutions**





# REFRIGERATED TRAILERS

## Model 5 x 10 Trailer

### PRODUCT SPECIFICATIONS

#### Name & Standard Model Numbers

Name:	5x10 Multi-Temp w/ Trailer
Auto Defrost - R404a:	5x10 ADT

#### Dimensions & Capacities

7 lb. Ice Bags - Auto Defrost:	520
20 lb. Ice Bags - Auto Defrost:	200
Approx. Interior Cubic Feet:	285
Exterior Dimensions (L"xW"xH"):	120 x 60 x 88
Interior Dimensions (L"xW"xH"):	114 x 54 x 80.75
Door Opening Dimensions (W"x H"):	78.70 x 50.75
Dimensions w/ Trailer (L"xW"x H"):	191.30 x 87.50 x 106.5

#### Operating Temperature

(X°F - X°F):	-4 to +40
Factory Presets:	Cooler, Freezer, or Ice
Adjustable Temperature:	Yes
Control:	Electronic

#### Electrical

Voltage (V/Hz):	120/60
Min. Circuit Required (Amps):	20

#### Trailer

Trailer Available:	Yes
GVWR (lbs):	9,995
Axels:	5,200 (Dual)
Payload:	7,000

#### Other

Compressor (HP):	1.25
Compressor Type:	Scroll Compressor
Auto Defrost Fan Type:	ECM Fans
Refrigerant:	R404a
Certifications:	NSF, UL, ULC

### FEATURES & BENEFITS

- Multi-temperature unit capable of consistent and reliable temperatures between -4°F to +40°F.
- Verified to perform and hold temperature at ambient temperatures up to 120°F.
- 1.25HP Scroll Compressor and EC Evaporator Fans provide reliable, efficient, and superior refrigeration performance.
- Interior capacity re-designed to easily store two full pallets.
- Largest door opening in the industry.
- Pallet-jack-rated reinforced steel floor with composite subfloor for greater durability.
- Precision machine formed patented cabinet construction.
- Available with integrated trailer!



### DIMENSIONAL DRAWINGS

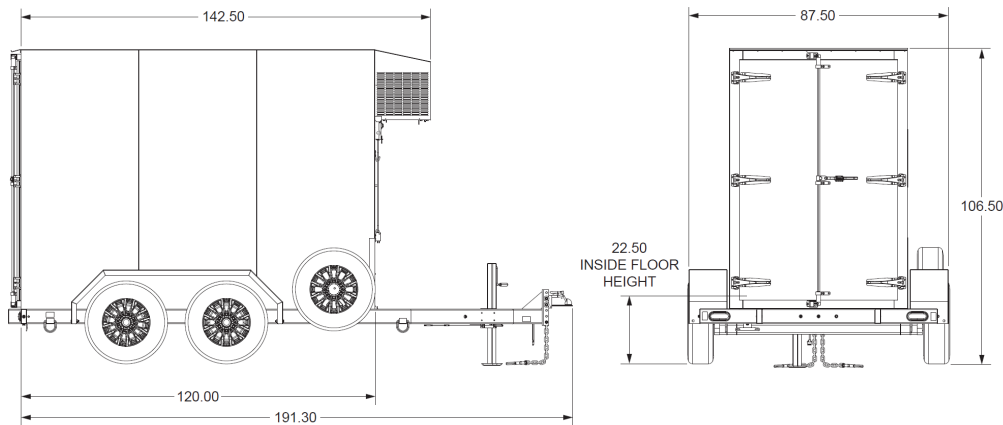

1. Depth Does Not Include Compressor  
 2. Add 3.5" to Depth for Handle & Hinges  
 3. Trailer storage capacities are approximate and may vary due to type of ice, bag size, and methods of loading.